

Electricity Markets Working Papers

WP-EM-26

A Dynamic Incentive Mechanism for Transmission Expansion in Electricity Networks – Theory, Modeling and Application

Juan Rosellón and Hannes Weigt

February 2008



Dresden University of Technology



Chair for Energy Economics and
Public Sector Management

A Dynamic Incentive Mechanism for Transmission Expansion in Electricity Networks – Theory, Modeling and Application¹

JUAN ROSELLÓN

**Centro de Investigación y Docencia Económicas (CIDE) and University of Technology
Dresden (TU Dresden)**

AND

HANNES WEIGT

University of Technology Dresden (TU Dresden)

Abstract

This paper examines the Hogan-Rosellón-Vogelsang (2007) (HRV) incentive mechanism for transmission expansion, and tests it for different network topologies. This new mechanism is based upon redefining transmission output in terms of point-to-point transactions or financial transmission rights (FTRs) and applies Vogelsang's (2001) incentive-regulation logic that proposes rebalancing the variable and fixed parts of a two-part tariff to promote efficient, long-term expansion. We analyze three main topics: first, the behavior of cost functions for distinct network topologies; second, the HRV regulatory approach (incorporated into an MPEC Problem and tested for a three-node network), and third an application to a simplified network. The results suggest that the mechanism is generally suited as an incentive tool for network extensions.

Key words: Electricity transmission expansion, incentive regulation, merchant investment, congestion management, Europe.

JEL-code: L51, L 91, L94, Q40

¹ Earlier versions were presented at: Infraday Berlin 2007; IDEI/Bruegel conference "Regulation, Competition and Investment in Network Industries" Brussels 2007; and Transatlantic Infraday Washington 2007. We acknowledge Andreas Ehrenmann, Christian von Hirschhausen, Ingo Vogelsang, and Bert Willems for their helpful comments. The usual disclaimer applies.

1 Introduction

1.1 Motivation

This paper analyzes a new tool for transmission expansion called the Hogan-Rosellón-Vogelsang (2007) (HRV) incentive mechanism. It is based upon redefining the output of transmission in terms of point-to-point transactions or financial transmission rights (FTRs) and applies the incentive-regulation logic in Vogelsang (2001) that proposes rebalancing the variable and fixed parts of a two-part tariff to promote efficient, long-term expansion. Roughly speaking, Vogelsang (2001) is by its nature relevant for radial networks only, while HRV is designed to deal with expansions within meshed networks.

Efficient transmission extension is one of the main concerns in restructured electricity markets around the world. In the US, network congestion is managed according to the different existing electric power systems. In regions with vertically integrated utilities, where restructuring has not taken place, a procedure which physically manages constraints by rationing access to portions of the transmission network is used. This procedure is known as transmission loading relief (TLR). Other areas in the US function under Independent System Operators (ISO) or Regional Transmission Organizations (RTO), which generally use market-based methods to manage congestion and promote the expansion of the network.² In both types of systems, congestion problems have arisen, in particular since the beginning of restructuring. The frequency of TLRs has risen considerably; this was particularly the case in the Midwest (Dyer, 2003). In other regions, too, congestion costs have increased, such as in the PJM, Southern Connecticut and New England markets. The Department of Energy (2006) identifies two critical congestion areas in economic important regions for the US: the Atlantic coastal area from metropolitan New York southward through Northern Virginia, and Southern California. Furthermore, four congestion areas of concern have been identified: New England, the Phoenix – Tucson area, the Seattle - Portland area, and the San Francisco Bay area. Transmission investment has declined during several recent periods (Joskow, 2005). The US regulator, FERC, has suggested policies on transmission investment based on the use of merchant transmission mechanisms, but not much effort has been carried out to apply performance-based regulatory mechanisms. Implementation of regulatory measures by the regulatory authority is further complicated by the duality of attributions at the federal and state levels.³

Developing sufficient network extensions, particularly cross border capacities, is also urgently needed in Europe. Due to the liberalization processes initiated in the late 1990s, existing national electricity networks with limited cross-border capacities now form the backbone of the emerging European-wide

² RTOs schedule and dispatch generators on regional networks, allocate scarce transmission capacity, monitor generators, coordinate maintenance to transmission networks, plan ways to develop new transmission links, and operate real time and diverse time-ahead markets for energy and ancillary services.

³ The states are responsible for reviewing applications for major new transmission facilities, granting permits and regulating charges for bundled transmission service charged by vertically integrated firms to retail customers. FERC is responsible for regulating the prices for transmission service, but has in general no authority over transmission planning.

internal market. However, the grid remains segmented into several regional and national sub-networks, resulting in little or no competition between countries, and the region as a whole is experiencing more congestion. The diverging policy approaches suggested for regulating transmission and managing congestion further complicate the development of a functioning electricity market. In addition, the expected capacity increase in renewables (primarily offshore and onshore wind) will require significant transmission investment. Although several studies have proposed ambitious extension schedules for the existing grid (e.g. Dena, 2005), an economical-technical approach that can cope with the increasing need for expansion while simultaneously accounting for welfare effects has not yet been designed. We propose that the HRV incentive mechanism is ideally suited to addressing these concerns.

After a brief theoretical overview, our paper is divided into three sections. First, we carry out a theoretical analysis of the cost function behavior of transmission expansion with simple structures (such as three-node meshed networks), and then extend them to more complex topologies. We focus on two basic cases: line capacities are adjusted, but nodes, lines, impedances and thus the power transmission distribution factors (PTDFs) do not change. Subsequently, we single out the effect of loop flows on costs by considering switched networks of the same topology (allowing for changes in line impedances that are correlated with line capacities) under several scale assumptions. These cases provide insights about the relationship between PTDFs and network topology size and shape. Second, we apply the HRV incentive mechanism to the theoretical network used for the first part of our cost-analysis to derive the general behavior of such a mechanism. We test the same differentiations made for the cost function analysis under the regulatory regime. Third, we apply the new incentive mechanism to a simplified grid (Germany, the Benelux and France) to test whether the theoretical conclusions we obtained are consistent with the application to a real-world situation.

1.2 Survey of the Literature

The two distinct theories of transmission investment take either a merchant approach (long-run financial rights to transmission, LTFTR), or a regulatory approach (incentive-regulation hypothesis).

The first is based on LTFTR auctions by an independent system operator (ISO). This approach is also known as a merchant mechanism because the participation of economic agents in auctions is voluntary. It addresses loop-flow externalities by having the ISO retain some unallocated transmission rights (or *proxy* FTRs) during the LTFTR auction to protect FTR holders from the negative externalities of transmission expansion projects (Kristiansen and Rosellon, 2006). This is equivalent to having the agents responsible for externalities “pay” them back (Bushnell and Stoft, 1997) so that when FTR contracts exactly match dispatch, welfare cannot be reduced through gaming.

The regulatory approach involves a commercial transmission company (Transco) that is regulated through benchmark regulation or price regulation to provide long-term investment incentives while avoiding congestion. Some mechanisms suggest comparing the Transco’s performance with a measure of welfare loss (Léautier, 2000, Grande and Wangesteen, 2000, and Joskow and Tirole, 2002). Another regulatory variation is the two-part tariff cap proposed by Vogelsang (2001), where incentives

for investment in expanding the grid derive from the rebalancing of the fixed and variable portions of the tariff. Vogelsang postulates transmission cost and demand functions with fairly general properties and then adapts regulatory adjustment processes to the electricity transmission problem. For example, under well-behaved cost and demand functions, appropriate weights (such as Laspeyres weights) grant convergence to equilibrium conditions.⁴ A particular criticism of this approach has been that the properties of transmission cost and demand functions are little known but are suspected to differ from conventional functional forms. Hence Vogelsang's assumed cost and demand properties may actually not hold in a real network context with loop-flows. Furthermore, a conventional linear definition of the transmission output is in fact difficult since the physical flow through a meshed transmission network is complex and highly interdependent among transactions (Bushnell and Stoft, 1997, and Hogan, 2002a, 2002b).

The new HRV mechanism combines the merchant and regulatory approaches in an environment of price-taking generators and loads. It is an extension of Vogelsang (2001) for meshed projects. It is designed for Transcos but – as in the Vogelsang (2001) model – it could also be applied to an ISO setting. Transmission output is redefined in terms of incremental LTFTRs in order to apply the Vogelsang incentive mechanism to a meshed network. The Transco maximizes profits intertemporally, subject to a price cap constraint on its two-part tariff, and the choice variables are the fixed and the variable fees. The fixed part of the tariff plays the role of a complementary charge. The variable part of the tariff is the price of the FTR output, and is then based on nodal prices. Pricing for the different cost components of transmission do not conflict (fixed costs are allocated so that the variable charges are able to reflect nodal prices). Thus, variations in fixed charges over time partially counteract the variability of nodal prices, giving some price insurance to the market participants.

The scientific results of the HRV model so far show convergence to marginal-cost pricing under idealized weights, while under Laspeyres weights there is evidence of such a convergence in more restrictive conditions.^{5,6} Likewise, transmission cost functions are shown to have very normal economic properties in a variety of circumstances. This holds, in particular, if the topology of all nodes and links is given and only the capacity of lines can be changed, which implies that unusually behaved cost functions require a change in the network topology.

⁴ See Rosellón (2007) for an application of the Vogelsang (2001) model to an electricity network with no loop flows.

⁵ Laspeyres weights are easily calculated and have shown nice economic properties under stable cost and demand conditions. Idealized weights correspond to perfectly predicted quantities and possess strong efficiency properties (see Laffont and Tirole, 1996, and Ramírez and Rosellón, 2002).

⁶ Under Laspeyres weights (and assuming that cross-derivatives have the same sign), prices will intertemporally converge to marginal costs if goods are complementary and prices are initially above marginal costs. When goods are substitutes, this effect is only obtained if the cross-effects are smaller than the direct effects. The opposite results are obtained if prices are below marginal costs.

2 Cost function behavior of transmission expansion

2.1 Outline

In this section we derive properties for electricity transmission cost functions. We identify types of network topologies where the expansion project derives from well- (or ill-) behaved transmission cost functions. In the first case, the expansion is such that only line capacities are adjusted, but nodes, lines, impedances and thus the PTDFs do not change. In the second case, the expansion considers switched networks of the same topology, allowing for changes in PTDFs and under several scale assumptions. Our analysis of cost functions relies on a “translation” of the HRV’s theoretical cost model into an empirically testable model. The HRV cost model defines cost function as the minimum costs necessary to produce each level of the FTR output subject to constraints on feasibility and on the relationship between FTR obligations and net injections:

$$C(FTR) = \min_{k_i} \sum_{i,j} f_{ij}(k_{ji}) \quad (1)$$

$$s.t. \quad -H^*q \leq k \quad (2)$$

$$q = FTR * e \quad (3)$$

with

FTR = $[q_{ij}]$ matrix of balanced point-to-point FTRs

q = vector of net injections

k = vector of line capacities

$f_{ij}(k_{ij})$ = cost of extending the capacity k_{ij} of the line connecting i and j ⁷

e = a vector of ones

H = PTDF matrix

$-H^*q$ = vector of line flows

The objective of our model is to satisfy a given combination of FTRs by estimating the least-cost capacity extension. Due to the loop-flow characteristics of electricity networks, an increased injection at one node may result in a decreased capacity requirement for specific lines. In the second case of our study, capacity extensions are linked to changes in the lines impedance resulting in a transformation of the grid’s PTDF. Thus whenever the capacity value of one line is changed the entire power flow within the grid differs and may cause congestion elsewhere.

Our goal is to derive a “global” cost function in terms of the individual lines’ costs. This is achieved by allowing one FTR output to move while keeping the others constant for the varied assumptions we make about the shape of individual-line cost functions.

⁷ Hereafter referred to as “extension function” whereas $C(FTR)$ is referred to as “cost function”.

2.2 Model approach

We incorporate the approach described into GAMS as a non-linear minimization problem, with the overall grid extension costs as an objective function. We use the DC Load Flow model to calculate power flows. Based on the assumption that real power flows are determined according to the differences of the voltage angles between two nodes, we can model the real flow by focusing only on the voltage angle differences (Stigler and Todem, 2005, and Schweppe et al., 1988). Doing so will avoid having to recalculate the PTDF matrix when changing a single line parameter since the line's reactance is already part of the flow formulation

$$P_{ij} = B_{ij} \cdot \Theta_{ij} \quad (4)$$

with

P_{ij} = real power flow between i and j

Θ_{ij} = voltage angle difference between i and j

B_{ij} = line series susceptance $\left(B_{ij} = \frac{X_{ij}}{X_{ij}^2 + R_{ij}^2} \right)$, with X_{ij} line reactance and R_{ij} line resistance⁸

For the specific capacity extensions represented by the functions $f_{ij}(k_{ij})$, we test three different forms corresponding to the constant, increasing and decreasing returns to scale:

Linear function: $f_{ij} = a_{ij} k_{ij} + c$

Quadratic function: $f_{ij} = a_{ij} k_{ij}^2 + c$

Logarithmic function: $f_{ij} = \ln(a_{ij} + b_{ij} k_{ij}) + c$

The values of a and b have been varied for different scenarios, and c is assumed to be 0. A realistic line extension function may be a combination of the three modeled cases (although linear extension costs are commonly used). We note the possibility of lumpiness of investments and spikes within the extension functions (e.g. due to a change in voltage level) (see also Section 2.3.3).

Our initial grid topology comprises a three-node network with two generation nodes and one demand node (Figure 1). We define two FTRs: from node 1 to 3 and from node 2 to 3. Both vary between 1 MW and 10 MW respectively to estimate the resulting global cost function. For the first part of the analysis we use a greenfield approach: lines reactances are given and fixed and the starting values for the line capacities are zero. Thus, for each incremental FTR we must construct the necessary capacity amount.

We alter the approach for the second part of our analysis when capacity and reactances are linked. The functional connection between capacity extensions and line characteristics $B_{ij}(k_{ij})$ is derived from the

⁸ As line resistance values are significantly smaller than the reactance values, only the latter are used within the model, simplifying the line susceptance to $B_{ij} = \frac{1}{X_{ij}}$

laws of parallel circuits.⁹ We assume that a doubling of capacity results in a bisection of a line reactance. Thus, starting values for the line capacities k_{ij} with a value of zero would result in an impossibility of any extension so we select starting values per line that allow a relatively high initial level of congestion and that are further reduced in the alternative case. Thus, the initial grid can only cover small amounts of FTRs (see Table 1). To further analyze the impact of loop-flow lines, we use a second configuration consisting of a meshed six-node network (Figure 2) and adjust the FTRs accordingly.

Due to the numerical nature of the model, we cannot make general predictions for cost functions applicable to any electricity network configuration, because specific grid configurations will produce quite different results. Nevertheless, by applying different scenarios for two different FTRs, we want to derive the functional behavior of extensions that can support general conclusions. Table 1 gives an overview of our simulation.

Figure 1: Three-node network

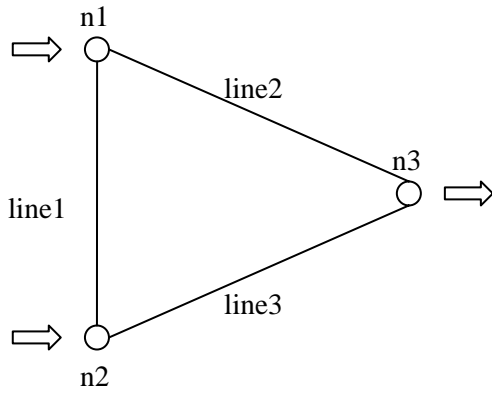

Figure 2: Six-node network

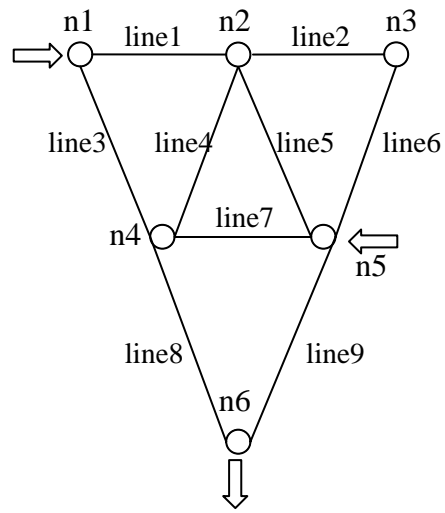

Table 1: Scenario overview for cost function calculation

	Fixed line reactances	Variable line reactances
Three-node network		
Considered FTR Range [MW]	FTR 1 to 3: 1 to 5 FTR 2 to 3: 1 to 10	
Considered Line Extension Functions	linear quadratic logarithmic	
Considered Line Extension	Base values: $a_{ij} = b_{ij} = 1$	Base values: $a_{ij} = b_{ij} = 1$

⁹ In a parallel circuit the total resistance of the system is defined by $R_{total} = \frac{1}{\sum_i \frac{1}{R_i}}$.

Functional parameters	Asymmetric case: a_{12} or $b_{12} = 3$	Asymmetric case 1: a_{12} or $b_{12} = 3$ Asymmetric case 2: a_{23} or $b_{23} = 3$
Starting capacity values [MW]	$k_{ij} = 0$	Base values: $k_{ij} = 2$ Alternative values: $k_{ij} = 1$
Six node network		
Considered FTR Range [MW]	FTR 1 to 6: 1 to 5 FTR 5 to 6: 1 to 10	
Considered Line Extension Functions	linear quadratic logarithmic	
Considered Line Extension Functional parameters	Base values: $a_{ij} = b_{ij} = 1$ Asymmetric case: a_{12} or $b_{12} = 3$ a_{23} or $b_{23} = 3$ a_{25} or $b_{25} = 3$ a_{35} or $b_{35} = 3$ a_{45} or $b_{45} = 3$	Base values: $a_{ij} = b_{ij} = 1$ Asymmetric case 1: a_{12} or $b_{12} = 3$ a_{23} or $b_{23} = 3$ a_{25} or $b_{25} = 3$ a_{35} or $b_{35} = 3$ a_{45} or $b_{45} = 3$ Asymmetric case 2: a_{14} or $b_{14} = 3$ a_{24} or $b_{24} = 3$ a_{46} or $b_{46} = 3$ a_{56} or $b_{56} = 3$
Starting capacity values [MW]	$k_{ij} = 0$	Base values: $k_{ij} = 2$ Alternative values: $k_{ij} = 1$

2.3 Results

2.3.1 Fixed line reactances

The first part of the cost function analysis only considers the capacity extension while the grid's topology is fixed in terms of line reactances and available connections. Varying the FTRs has an exogenously determined impact on the power flow pattern. Hence, our model only calculates the minimum capacity amount needed to exactly fulfill this pattern. The outcomes therefore resemble the loop-flow nature of real-world networks.

In the symmetric three-node case, line 1 (between nodes 1 and 2) is subject to power flows in opposite directions depending on the value of the two FTRs. Given a fixed level of one FTR, an increase in the second FTR will first lead to a decrease in the flow on line 1 towards zero until both FTRs have the same value. Afterwards, the flow will again increase, although in the opposite direction. The resulting cost for increasing the FTR value will show a "kink" at the level of the fixed FTR (Figure 3) that could imply some problems. Furthermore, the resulting global cost function for increasing two FTRs simultaneously shows that the costs when moving from one FTR combination to another can even decrease (Figure 4). This result is specific to the decreasing-returns extension function, since the cost always increases with increasing FTR values for both the linear and quadratic functions. The asymmetric case easily distinguishes the outcomes because the loop-flows' cost dependence can be represented clearly.

Figure 3: Cost function, three-node network, FTR 1>3 fixed at 2.5 MW

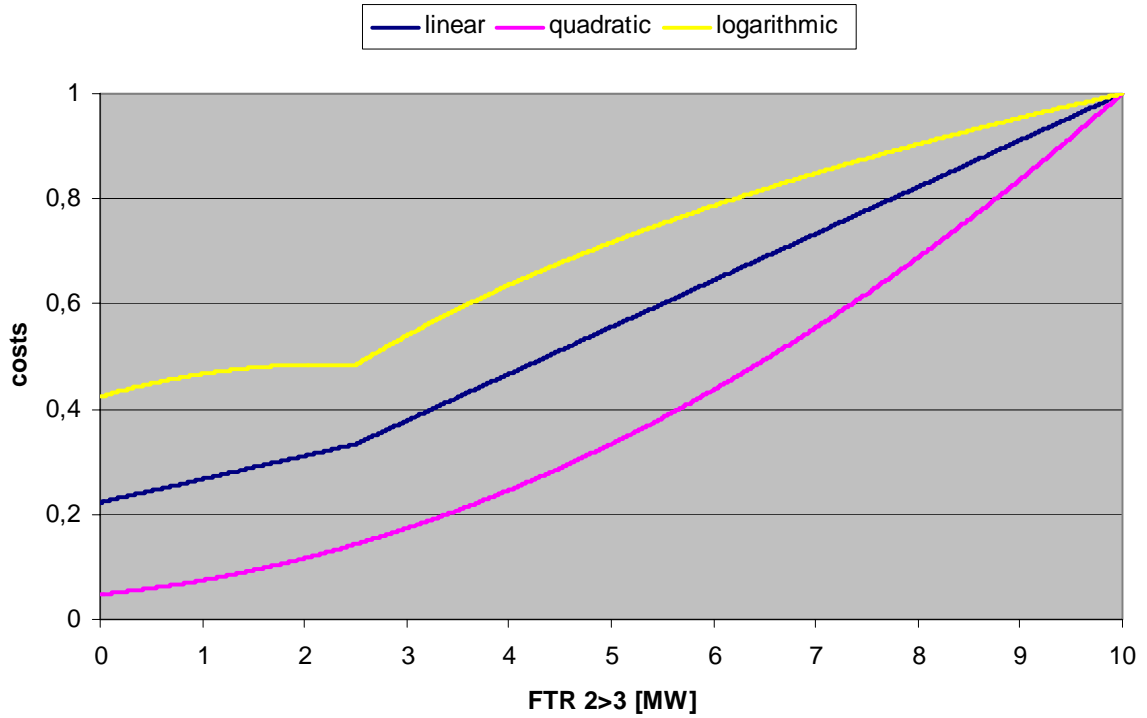
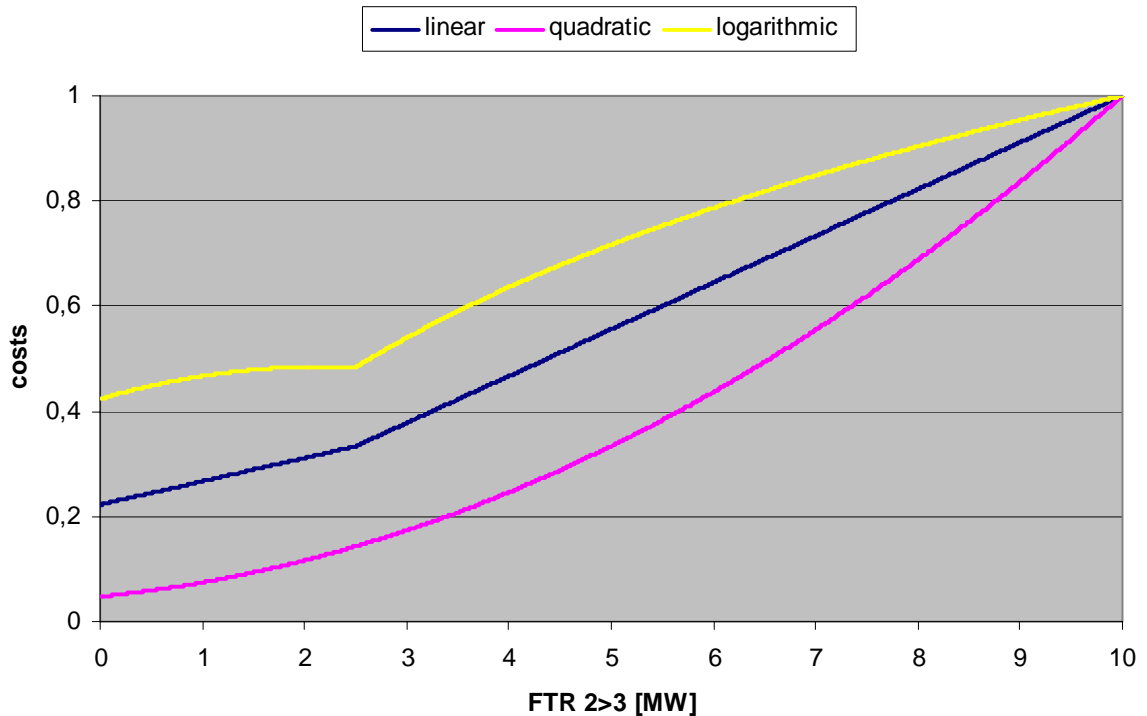

Figure 4: Global cost function, three-node network, logarithmic extension functions



Extending our model to six nodes according to the FTR combination subjects five lines to counter-flows. Since lines 2, 5 and 6 are symmetric, their counter-flows will “kink” at the same level. The resulting global cost function can have three kinks according to the FTR combinations. In comparing the six- and the three-node networks, the quadratic extension function still results in an always-

increasing feasibility range while the logarithmic function has a decreasing global cost function according to the FTR combination. However, the linear extension function also now has decreasing elements (Figure 5) in the global costs function, especially when increasing the cost parameters for loop-flow lines (asymmetric case). In other words, by extending a specific FTR, the simultaneous increase of further FTRs can reduce the overall costs in meshed networks. However, this will not always be achieved because the necessary counter-flow generating FTRs may not be needed and the positive effect of the additional net injections will not be obtained.

Figure 5: Global cost function, six-node network, linear extension functions, asymmetric case

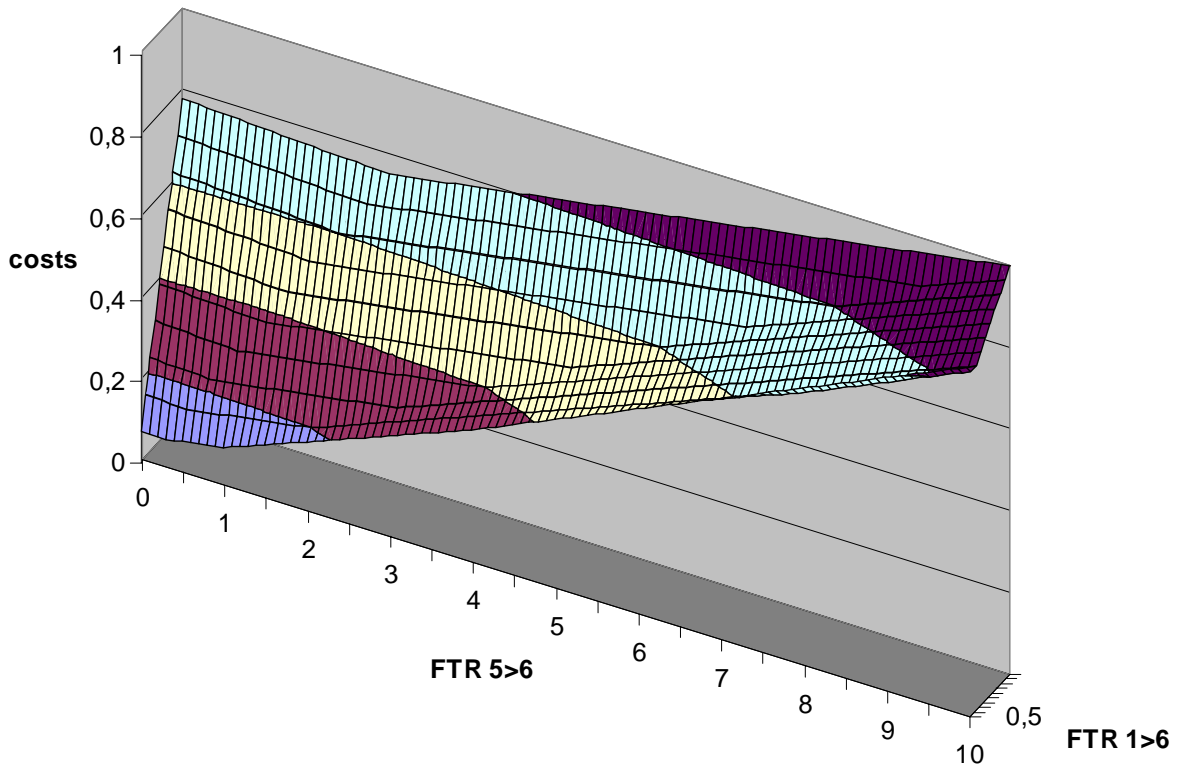

2.3.2 Variable line reactances

In reality, there are limitations to extending a line's capacity without altering its added technical characteristics. Normally, a capacity extension is linked to a change in the reactance of the line. Therefore, for the second part of our analysis, we assume that doubling a line's capacity results in a reduction of its reactance by the factor 0.5 (based on the law of parallel circuits). We observe that the starting values of the lines' capacities are necessary but that they will prevent making a direct comparison to our first approach that uses fixed-line reactances.

Using the simple three-node case and a starting capacity of 2 MW on each line, the resulting cost functions do not necessarily have a kink when one FTR is fixed. In addition, all lines start with zero extension costs since the first portion of the FTR increase can be accomplished with the existing grid (Figure 6). However, the cost function can still have kinks but these do not necessarily relate to a specific loop-flowed line. Discontinuities can also be caused by changing grid conditions as the same

FTR combination can now be obtained by several different extension measurements e.g. increasing two line capacities by modest amounts or increase only one line significantly.

The global cost function for extending both FTRs no longer shows a clear correlation with the number of loop-flowed lines as we observed in the fixed-reactance portion of our analysis. Moreover, all line extension functions show decreasing elements for certain FTR combinations (Figure 7). As the simulation needs starting values for line capacities, an alternative approach with reduced capacities has been calculated. However, when decreasing the starting capacity from 2 MW to 1 MW the resulting cost functions show a similar behavior. We note that the functions slightly shift to the left and that the outcomes of higher FTR levels vary accordingly.

Increasing the parameters of the costs function of the loop-flowed line will not alter the results. Thus, in the optimal solution of the three-node network, we appear to avoid an extension of line 1, but when we alter the cost parameters of another line, the outcome changes, although the general functional form remains similar. The logarithmic extension function yields different results as the trade-off between extensions of one or two lines becomes more evident (i.e. large extensions are relatively less expensive).

Figure 6: Cost function, three-node network, FTR 1>3 fixed at 2.5 MW, variable line reactances

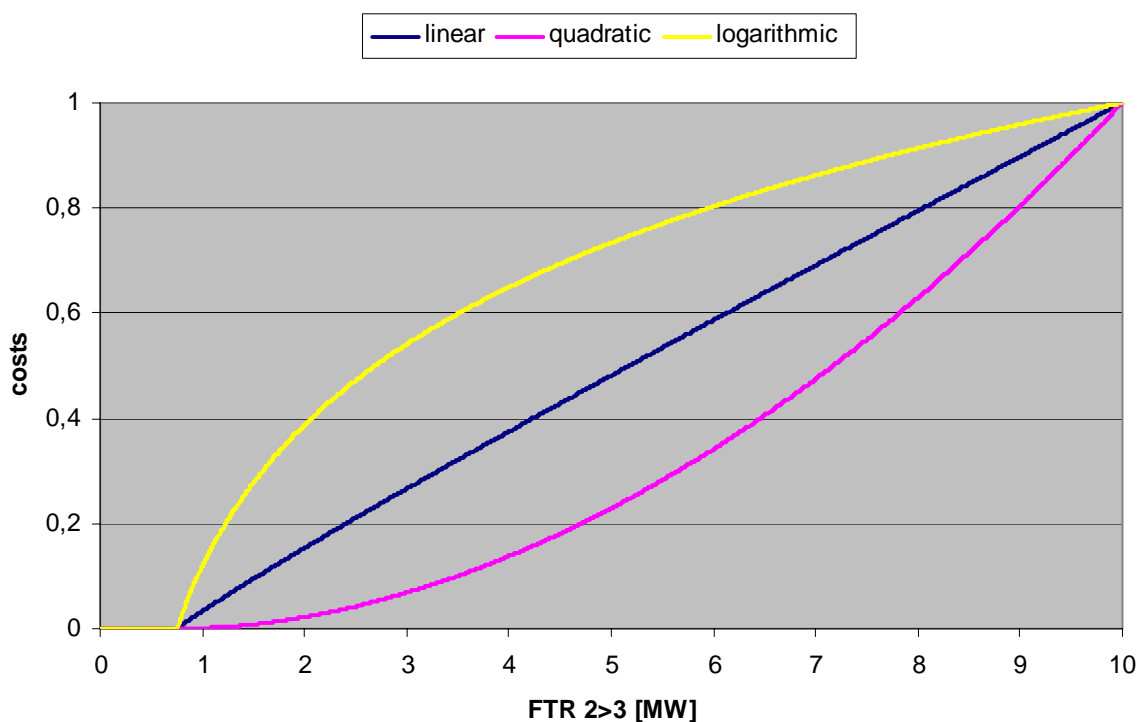
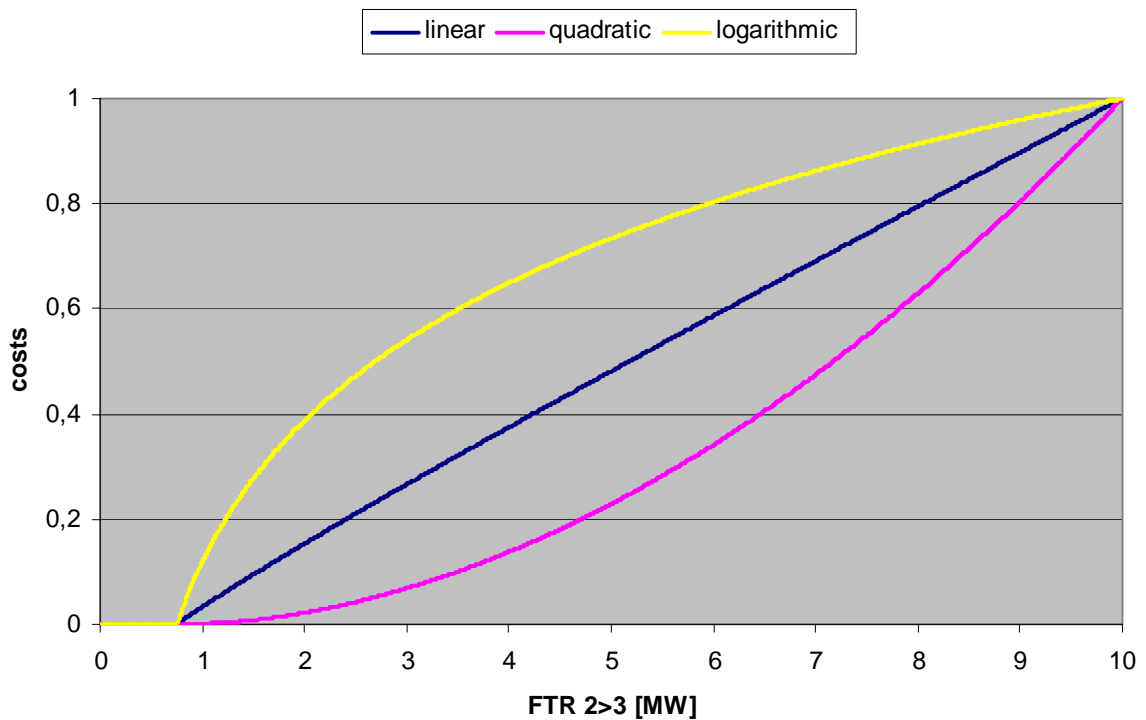

Figure 7: Global cost function, three-node network, logarithmic extension functions, variable line reactances



Next, our model is extended to six nodes and nine lines to estimate the impact of more loop-flowed lines on the cost functions. As in the three-node simulations, the obtained global cost functions do not reveal an obvious correlation to the number of loop-flowed lines. The results for linear and quadratic extension functions show a generally increasing cost function with a relatively smooth outline; however the logarithmic extension function results in a global cost function with significant slope changes (Figure 8). We note the difficulty in obtaining a consistent solution in the logarithmic case, resulting in cost spikes which occurred in three of the six scenario runs.¹⁰

Comparing the results with the fixed network case shows that the introduction of variable line reactances significantly changes the possible outcomes. In particular, for linear or quadratic extension functions, the introduction of a linkage between capacity and reactance appears to reduce the impact of loop-flows in terms of significant kinks.

¹⁰ Reducing the starting capacity of the lines to 1 MW does not significantly change the results of the linear and quadratic extension functions. The global cost function in the logarithmic case also resembles the same form but the slope changes are less pronounced. Likewise, a shifting of the line parameters for loop-flowed and non loop-flowed lines does not alter the general results although the absolute values differ.

Figure 8: Global cost function, six-node network, logarithmic extension functions, variable line reactances

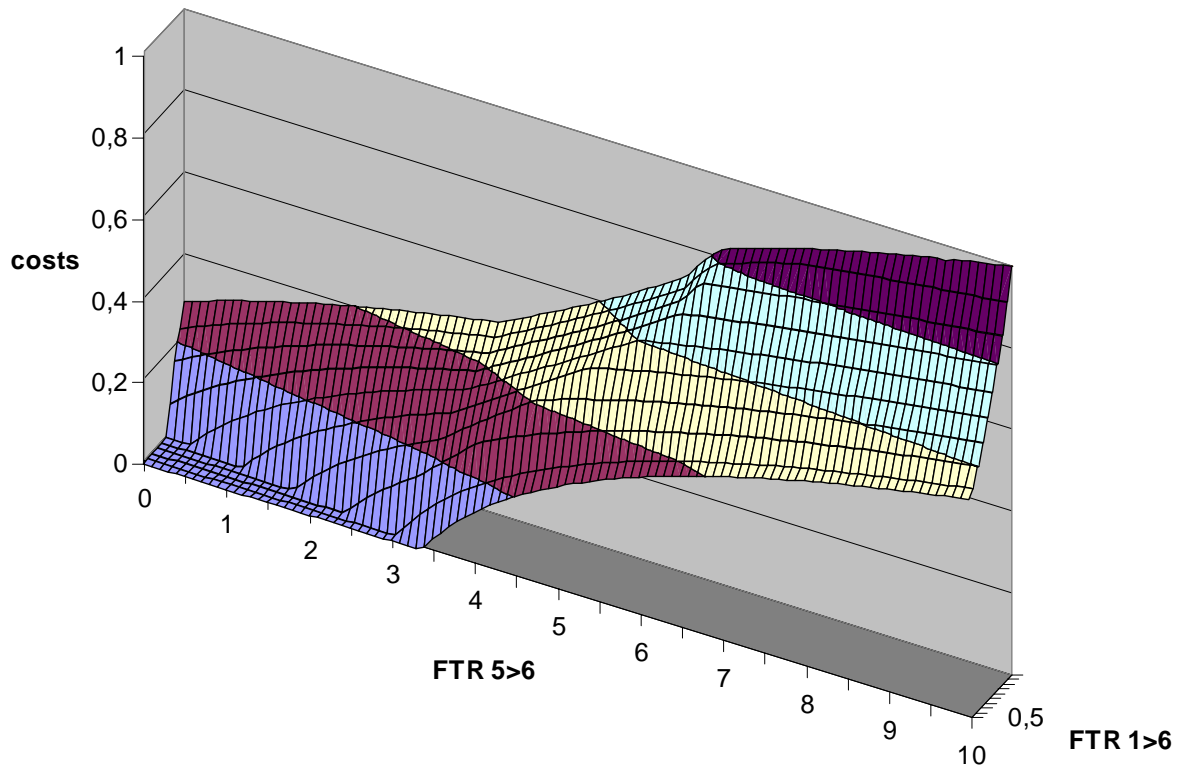

2.3.3 Conclusion

The results of our cost function analyses reveal the difficulties that electricity networks present when applying standard approaches. Even for a simple extension, loop-flows within the system can lead to mathematically problematical global cost function behaviors. We observe that the linkage between capacity extension and line reactances (and thus the flow patterns) produces complex results that are highly sensitive to the underlying grid structure. None of the three tested extension functions can fully reproduce realistic extension structures since these are subject to lumpiness and external influences (e.g. geographical conditions) that can cause dysfunctional behaviors with sudden slope changes. The assumption of linear extension costs is acceptable when considering line length; however with respect to capacity increase, a lumpy function with constant costs for corresponding voltage levels and circuit number is required.

For modeling purposes, the logarithmic behavior appears to produce a high degree of nonlinearities with non-smooth behavior, and demands more intense calculations and solver capabilities. Quadratic functions show a generally continuous behavior that makes them suitable for modeling purposes. Linear extension functions fall between the logarithmic and quadratic cases. However, the piecewise, linear nature of the resulting global costs function makes the derivation of global optima feasible; in combination with the advantages of retaining linear functions, this is preferred for modeling purposes and is compatible with the realistic extension costs neglecting lumpiness.

3 The regulatory two-part tariff model

3.1 Outline

Next we analyze the implementation of the HRV regulatory model to determine if it can provide incentives for efficient expansion. We estimate the impact of different assumptions regarding grid parameters and topology, again with and without PTDF changes. As in Section 3, we translate the HRV theoretical regulatory model (Hogan, Rosellón, and Vogelsang, 2007, pp. 13-19) into an empirically testable model.

The HRV regulatory model uses FTRs as the definition of output. Using this definition allows us to link the regulatory logic of a price cap constraint on two-part tariffs of Vogelsang (2001) to the merchant model. The HRV model assumes stable costs and demand conditions, and considers the repeated application of the incentive mechanism of a myopic Transco optimizing profit in each period. Likewise, there are various established agents (generators, Gridcos, marketers, etc.) interested in transmission expansion that do not have market power in their respective markets.

A sequence of auctions held at each period t where participants buy and sell LTFTRs, culminates in a real time auction at which time all FTRs are cashed out. LTFTRs are assumed to be point-to-point balanced financial transmission right obligations. The Transco maximizes expected profits at each auction subject to simultaneous feasibility constraints and a two-part-tariff cap constraint. The transmission outputs are the incremental LTFTRs between consecutive periods. Our model first defines the least cost solution for the network configuration that meets a given demand. For the domain where $t^t q = 0$ (i.e., no losses):

$$c^*(q, K^{t-1}, H^{t-1}) = \underset{K^t \in K, H^t \in H}{\text{Min}} \left\{ c(K^t, K^{t-1}, H^t, H^{t-1}) \mid H^t q \leq K^t \right\}. \quad (5)$$

where:

$$q^t = \text{the net injections in period } t \text{ (FTRs are derived from: } \sum_j \tau_j^t = q^t; \tau_j^t = \begin{bmatrix} -x \\ 0 \\ 0 \\ \cdot \\ \cdot \\ +x \\ 0 \end{bmatrix})^{11}$$

K^t = available transmission capacity in period t

H^t = transfer admittance matrix at period t

t^t = a vector of ones

$c(K^t, K^{t-1}, H^t, H^{t-1})$ is the cost of moving from one configuration to the next. For a DC load approximation model, the Transco's profit maximization problem is then given by:

$$\text{Max}_{\tau^t, F^t} \pi^t = \tau^t (q(\tau^t) - q^{t-1}) + F^t N^t - c(K^t, K^{t-1}, H^t, H^{t-1}) \quad (6)$$

subject to

$$\tau^t Q^w + F^t N^t \leq \tau^{t-1} Q^w + F^{t-1} N^t \quad (7)$$

where:

τ^t = vector of transmission prices between locations in period t

F^t = fixed fee in period t

N^t = number of consumers in period t

$Q^w = (q^t - q^{t-1})^w$

w = type of weight.

We note that the proposed price cap index (7) is defined for two-part tariffs as a variable fee τ^t and a fixed fee F where the output is incremental LTFTRs. The weighted number of consumers N^t is assumed to be determined exogenously. When the demand and optimized cost functions are differentiated, the first order optimality conditions are:

$$\nabla q(\tau - \nabla_q c^*) = Q^w - (q(\tau) - q^{t-1}) \quad (8)$$

3.2 Model approach

We view this incentive-regulatory mechanism as a maximization problem with complementarity constraints (MPEC) model that incorporates both a profit-maximizing Transco subject to the two-part tariff constraint and a perfectly competitive wholesale nodal pricing market. The Transco's revenue consists of the collected congestion rents and the fixed part of the tariff, and its expenses are the network investment costs. By choosing a specific extension level, the Transco has an impact on flow patterns and market prices and consequently on its own revenue.

For a first application of the HRV regulatory model we alter our approach to allow for a straightforward implementation into GAMS. The objective function of the Transco covers the collectable congestion rent in terms of point-to-point price differences (Δp_{ij}) in a nodal pricing market and its fixed fee minus the extension costs for the grid:

$$\max_{k, F} \pi = \sum_t \Delta p_{ij}^t q_{ij}^t + F^t N^t - c(k_{ij}^t) \quad (9)$$

The sum of the variable and fixed revenues is subject to a Laspeyere weighted price cap as proposed in equation (7). The time horizon is assumed to be ten periods. The first period is considered to define the starting values for the price cap and no extension measurements are allowed in. We also assume that

¹¹ 'q' refers to net injections of the form q_i , while the FTRs are of the form q_{ij} . The FTRs form a matrix $Q = [q_{ij}]$ so that the vector of net injections is $q = Qe$, where e is a unit vector. Since we are assuming that FTRs are point-to-point obligations, we can indirectly use net injections or FTRs as outputs (see Hogan, 2002b).

the starting value of F has an impact on the outcome by allowing the Transco a higher starting basis for grid extensions.

The Transco's maximization problem is subject to a market equilibrium that defines the outcome of the nodal pricing market. We assume a welfare maximizing ISO that balances demand and generation, given network constraints:

$$\max W = \sum_{i,t} \left(\int_0^{d_i^{t*}} p(d_i^t) dd_i^t - \int_0^{g_i^{t*}} c(g_i^t) dg_i^t \right) \quad (10)$$

$$\text{s.t.} \quad |P_{ij}^t| \leq k_{ij}^t \quad \text{line flow constraint between } i \text{ and } j \quad (11)$$

$$g_i^t - d_i^t - q_i^t = 0 \quad \text{energy balance constraint at node } i \quad (12)$$

$$g_i^t \leq g_i^{t,\max} \quad \text{generation constraint at node } i \quad (13)$$

where

t = time period

d_i = demand at node i

$p(d_i)$ = linear price function at node i

g_i = generation at node i

P_{ij} = real power flow between i and j

Demand and generation result in pairs of net inputs (q_i and q_j) that translate into specific FTRs between these nodes. Power flows are again calculated based on the DC-Load-Flow approach following equation (4). The power-flow welfare maximization problem is transformed into an equilibrium problem by deriving the first order conditions of the Lagrange formulation and their dual variables respectively. The wholesale market therefore is assumed to be fully competitive and the only influence that the Transco has on the market outcome is to decide on the extensions of existing lines.

Similar to the cost function analysis, we use a three-node network to test the HRV regulatory model for a fixed-PTDF grid and then for a linkage of line capacities and reactances. To mathematically simplify the analysis, we introduce linear demand functions at each node with a slope of -1 and a maximum demand of 10 at a price of 0. We assume that node 3 depends on the grid for supply. Generation capacities at nodes 1 and 2 are assumed to be unrestricted and have no marginal generation costs. Thus the demand at these nodes should always be at maximum level and supplied by local generation.

Since the first period defines the price cap, we expect that the results strongly depend on the chosen starting conditions, in particular the starting capacities of the lines. To test the impact of the starting conditions we also consider a second approach using asymmetric generation costs. Table 2 summarizes the calculated scenarios.

Table 2: Scenario overview for MPEC model

	Fixed line reactances	Variable line reactances
Time periods	$t = 10$	
Demand function at i	$p(d_i) = 10 - d_i$	
Considered Line Extension Functions	linear quadratic logarithmic	
Considered Line Extension Functional parameters	$a_{ij} = b_{ij} = 1$ $c_{ij} = 0$	
Starting capacity values	Base values: $k_{ij} = 2$ Alternative values: $k_{ij} = 1$	
Generation costs at i	Base values: $c_i = 0$ Alternative values: $c_i = 1$	
Starting value for fixed tariff part in t_l	Base values: $F^{t_l} = 0$ Alternative values: $F^{t_l} = 20$	

3.3 Results

3.3.1 Fixed line reactances

When using symmetric generation facilities, the obtained results of linear, quadratic, and logarithmic extension functions do not differ significantly in the fixed network. Prices at node 1 and 2 stay at zero thus equaling the marginal generation costs. The price at node 3 starts from either 6 €/MWh or 8 €/MWh depending on the starting line capacities and drops to about 5 €/MWh for all of the remaining periods. With the exception of the quadratic function, only one extension measurement is undertaken in period 2. In the quadratic case, extensions take place in each period although strongly decreasing in absolute values. However, the sum of the extended capacity is nearly equal for all three extension cases.¹²

For the asymmetric case, the results differ when we change the cost parameters of generation. The price at node 1 remains at its marginal costs level for all scenarios. In other words, the modeled Transco has no incentive to increase line capacities to allow for a price reduction due to the cheaper generation at node 2. Prices at node 3 again change according to the extended capacities. The quadratic extension function still results in a generally decreasing extension over all periods. The linear and logarithmic functions result in one, two or three price jumps and related extension measurements. The price at node 3 can drop to as low a value of 2 €/MWh for some of the scenarios. The total sum of extensions therefore is not constant as in the symmetric case, which could be a result of the greater non linearity resulting from asymmetric generation and non smooth extension functions. As time is not accounted for at full economic scale within the model the Transco is indifferent about revenues in

¹² It is not evident why the quadratic case shows a significant different behavior than the other two cases. A further non-intuitive result is that increasing the starting value for the fixed-part of the tariff does not alter the results.

present or future periods which might influence the obtained results. Again, introducing a starting fixed- part of the tariff does not alter the general outcome.

3.3.2 Variable line reactances

Under base case conditions with 2 MW starting line capacities, symmetric generation, and no fixed-part of the tariff, the resulting price and extension patterns in the first period resemble the expectations of a price decrease towards marginal costs. While prices tend towards marginal generation cost due to increasing line extensions, the loss of congestion rent is compensated for by increasing the returns of the fixed-part of the tariff (Figure 9). The results for linear and logarithmic extension functions show only small differences whereas the quadratic case has a slightly different functional form towards the last periods with a further steady decrease. Reducing the starting capacity does not vary the results although the absolute values differ. The extension schedule for the quadratic case is symmetric for all periods. By contrast for linear and logarithmic extension functions, the values are chiefly symmetric or focus on the capacity of a single one line.

Introducing asymmetric generation costs leads to a significant divergence in the functional form of the quadratic extension case whereas the other two extensions cases remain rather stable (Figure 10). The price at node 1 with its higher marginal generation costs and the price at node 2 decrease. In the linear and logarithmic cases the price at node 2 moves towards 0 starting in period 3. In the quadratic case the price decrease starts in period 7 but also reaches 0 in period 10. Altering the starting value of the fixed-part of the tariff does not change the results again and decreasing the starting capacity changes the absolute value but not the general behavior. The extension schedule of the quadratic case is more consistent since it continuously extends lines 1 and 2. In the linear and logarithmic extension cases, capacities increase with the larger amounts in the first periods which explains the divergence of the price figures. The total amount of extension is similar in all three cases.

The major difference between the static and variable line reactances is the non-existent price movement in the first case. Furthermore, the fixed-part of the tariff is not altered during the periods. Thus the Transco extends only to prevent changes in the initial congestion rent value even though more energy is transmitted. The missing possibility of changing the grid's flow pattern in effect limits the Transco's choices to the observed ones. In reality, capacity extension is generally linked to changes in a network's flow characteristics, making the second part of our analysis particularly relevant. Altering the original postulated myopic assumption of the Transco may also bias the results. A Transco that maximizes repeatedly in one period may have very different incentives from one that considers all periods. However, a periodic approach may still be more appropriate.¹³

¹³ One must bear in mind the complexity of solving MPEC and the high degree of nonlinearity in the used functions. The resulting non-smooth behavior increases the possibility that the obtained solutions are local optima.

Figure 9: Variable part of the tariff price at node 3 and fixed-part of the tariff, variable line reactances, and symmetric generation

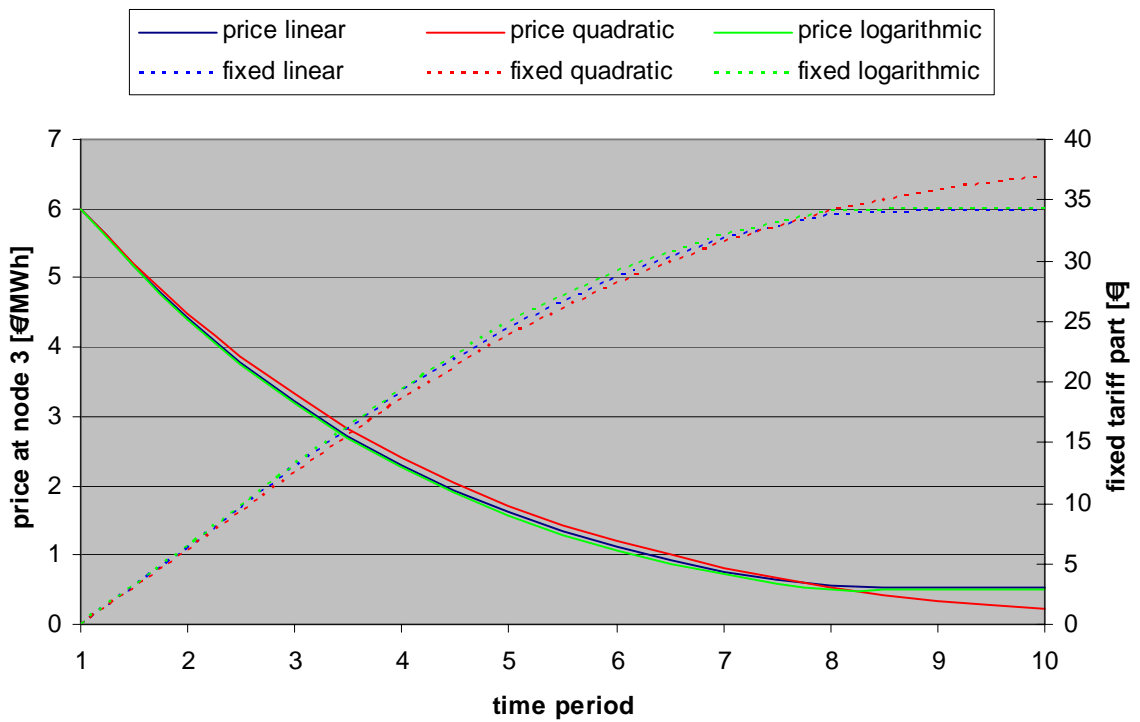
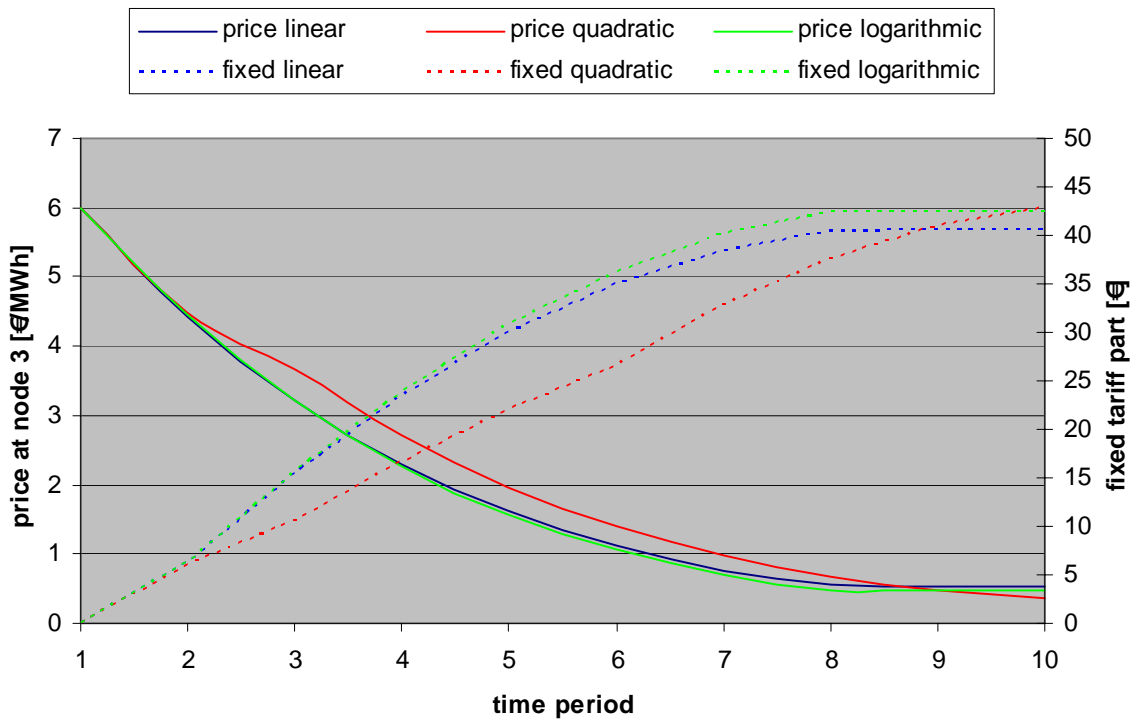

Figure 10: Variable part of the tariff at node 3 and fixed-part of the tariff, variable line reactances, and asymmetric generation



4 Application to a European Network

4.1 Outline

We now test the theoretical insights obtained. Figure 11 illustrates a simplified grid connecting Germany, the Benelux, and France as presented in Ehrenmann et al. (2006). The modeled market is designed as a nodal pricing system, characterized by high prices in the Benelux, intermediate prices in Germany, and relatively low prices in France. The simplified transmission network gives a good “snapshot” of the European market’s congestion problems.

Figure 11: Simplified grid of North West Europe

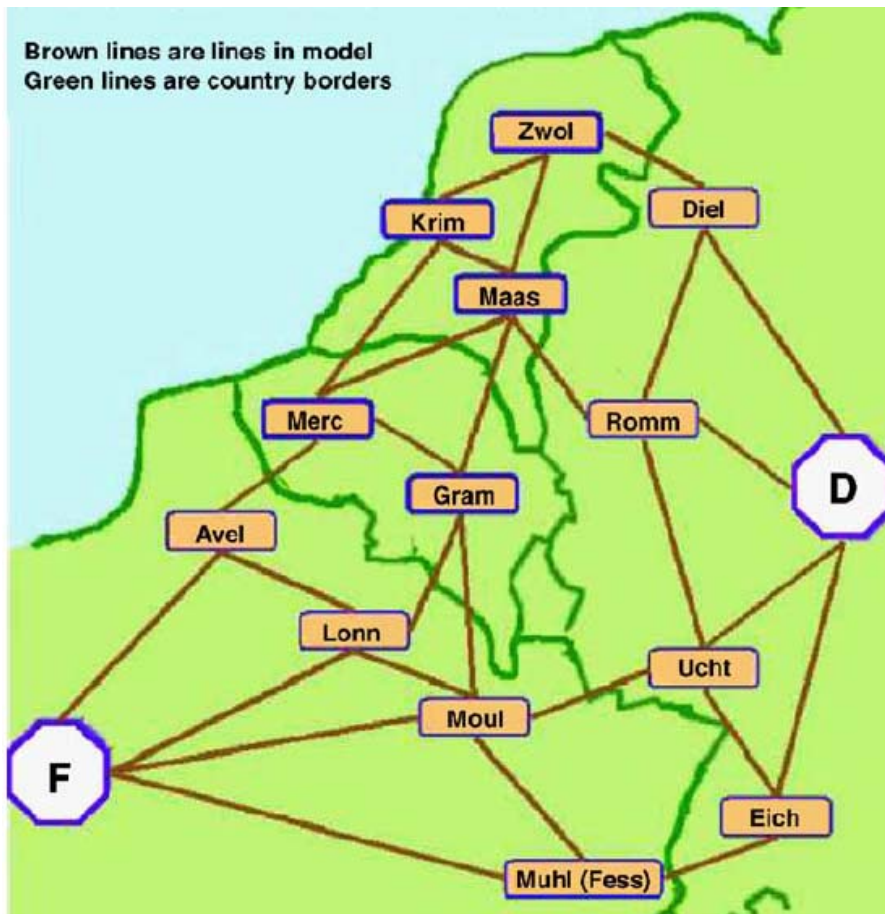

4.2 Model and Data

Our model’s mathematical implementation follows the approach presented in Section 3.2 with variable line reactances. The only difference is the introduction of plant types to differentiate several plants at one node i . We adjust the dataset to represent the simplified network of 15 nodes and 28 lines. The nodes connecting France and Germany with their neighbors are auxiliary nodes without associated demand or generation. The lines connecting the German and French nodes with these auxiliary nodes are assumed to have unlimited capacities, and the Transco is not permitted to extend them. Each country node has given generation capacities and a reference demand level. For additional simplification, we classify generation capacities by eight types and assume an equal marginal cost level for each type in all countries. Table 3 gives an overview of the types, installed capacities, and

marginal generation costs. A linear demand behavior at one node is derived from the average load level and an assumed price elasticity of -0.25.

The line extension costs are assumed to behave linearly. Following Brakelmann (2004) and DENA (2005), we choose a value of 100 € per km per MW. This value is derived from upgrade costs for additional lines of the same voltage level, and upgrades from 220 kV to 380 kV (in reality, network investments are lumpy; adding one more line adds a specific amount of capacity to the system). The derived results for one time period represent one hour; thus the obtained Transco revenue is multiplied by 8760 for each of the 10 periods to resemble yearly incomes. Due to the average nature of both the load level and the generation structure, our model omits the variable nature of real-world electricity systems.

The starting conditions in the market are classified by a high price level in the Netherlands (Krim, Mass, Zwol), a divided price structure in Belgium (Grim, Merc), modest prices in Germany, and low prices in France. Thus, congestion occurs between Belgium and France, as well as between Germany and the Netherlands.

Table 3: Plant characteristics

Plant type	Installed capacity	Marginal generation cost	Plant type	Installed capacity	Marginal generation cost
Nuclear	83 500 GW	10 €/MWh	Steam	28 000 GW	45 €/MWh
Lignite	21 000 GW	15 €/MWh	Gas turbine	5 500 GW	60 €/MWh
Coal	51 250 GW	18 €/MWh	Hydro	17 000 GW	0 €/MWh
CCGT	18 500 GW	35 €/MWh	Pumped storage	13 000 GW	28 €/MWh

4.3 Results

We modeled a ten-period run and achieve an extensive network extension program that leads to price convergence at the marginal costs level of coal units (Figure 12). The fixed-part of the tariff increases in a similar fashion to the cases presented in Section 3.3.2. The Transco's profit increases during the periods, starting at 950 mn € per year, and reaching 2.5 bn € in the last period. Thus the chosen Laspeyres weights allow a significant revenue increase for the Transco.

The extension amount totals an additional 14.2 GW, or nearly 43% of the system's initial line capacity. The relatively low total investment of about 140 mn is explained by our assumption that the extension cost functions represent system upgrades only and no new connections are built. The geographic extent of the extensions (Figure 13) resembles expectations drawn from the nodal price differences, particularly between France and Belgium. However, some of the measures appear to represent necessary back-up extensions to allow for specific flow patterns between France and Germany and within Germany.

The consumer surplus in the system also changes according to the price development. Due to the large demand levels in France which faces higher prices after the extensions, the surplus decreases by 1%. We observe that although the overall congestion nearly vanishes, the increased consumer surplus in the Benelux is insufficient to offset the decrease in France. However, looking at the social welfare including consumer and producer surplus of the wholesale market, we see an increase of 1.7% (equal to almost 1.6 bn € annually).

These preliminary results show that our mechanism has the potential to foster investment in congested networks in a welfare-improving direction. However, more analysis is necessary to estimate the impact of externalities (e.g. wind input and generation extensions) on the Transco's behavior. Furthermore, the extension functions and restrictions must be adjusted to more completely reflect real conditions, especially the lumpiness of investments. These adjustments may result in serious modeling problems due to the non-linear and non-smooth nature of the impacts. Political and administrative issues to be addressed include property-right issues and existing, long-term transaction contracts.

Figure 12: Price development in the European model

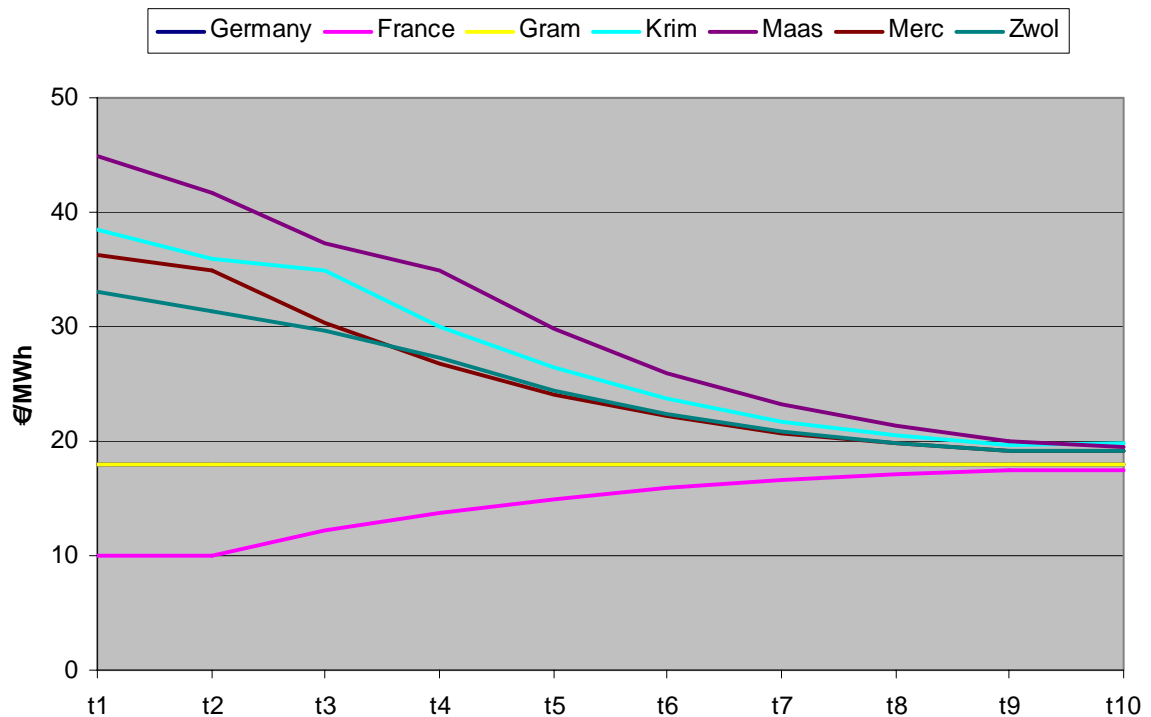
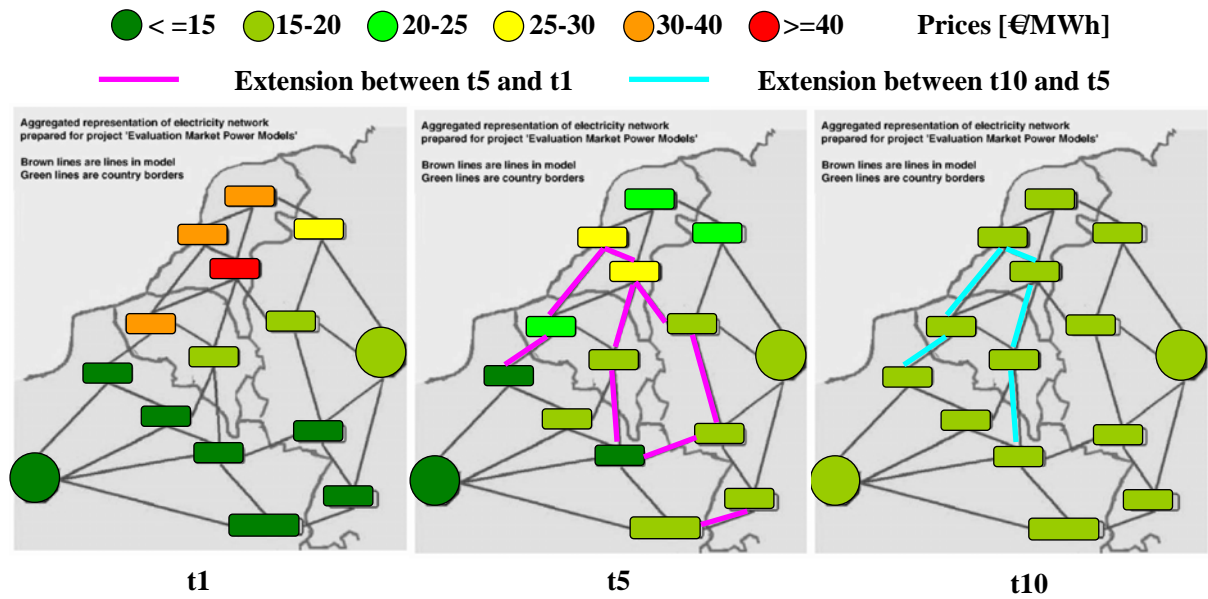

Figure 13: Geographical price structure of the model



5 Conclusions

This paper presents a combination of the merchant-FTR and the regulatory approaches to transmission expansion in a competitive environment of price-taking generators and loads. We are interested in the application of incentive mechanisms and their compatibility with merchant investment in organized electricity markets with FTRs.

The paper discusses three distinct topics and our preliminary results. First, the general cost function behavior in electricity networks is analyzed. Due to the loop-flow nature of meshed networks, a high level of complexity, non linearity and discontinuities exist. We apply increasing, linear, and decreasing extension functions for lines within a network in order to derive the global cost function when increasing the FTR in the system. The results indicate that the high level of kinks resulting from loop-flows on lines diminishes when line capacity extensions are linked to line reactances (i.e. changing the flow pattern within the network whenever it is extended). However, the resulting global cost functions still show a high level of nonlinearity, and complicating the derivation of global optima in model approaches.

Second we implement a regulatory mechanism as an MPEC problem with a profit maximizing Transco and a fully competitive wholesale market based on nodal pricing. Starting with a congested grid, the Transco is free to choose grid extensions that influence its own profit (the congestion rent and a fixed fee). The Transco's profits are subject to a price cap with Laspeyres weights. The results show that the Transco extends the network and that prices converge towards marginal costs over the periods. Third, we test the MPEC approach using the simplified grid of Northwestern Europe with a realistic generation structure. This first application of the HRV mechanism to a real world situation yields outcomes similar to our theoretical simulated analyses; the nodal prices that were subject to a high

level of congestion in the first phase converge towards a common price level representing the marginal generation costs.

We suggest that additional analyses are necessary to verify the obtained results and general conclusions presented. At a minimum, they should include improving the underlying model structure with respect to myopic behavior; varying the weights in the price-cap constraint; altering the time periods; employing variable pricing mechanisms (particularly zonal pricing); and examining the impacts of additional Transcos within one network.

References

- Bushnell, J. B., and S. E. Stoft (1997) "Improving Private Incentives for Electric Grid Investment," *Resource and Energy Economics* 19, 85-108.
- DENA (2005): *dena-Netzstudie, Energiewirtschaftliche Planung für die Netzintegration von Windenergie in Deutschland an Land und Offshore bis zum Jahr 2020*. Deutsche Energie-Agentur.
- Department of Energy (2006): *National electric transmission congestion study*. August 2006.
- Dyer, Jim (2003): *U.S. Department of Energy Transmission Bottleneck Project Report*. Consortium for Electric Reliability Technology Solutions (CERTS)
- Ehrenmann, A., G. Oggioni, I. Rumiantseva and Y. Smeers (2006), "Introduction of CO2 Emission Certificates in a Simplified Model of the Benelux Electricity Network with Small and Large Consumers," Working Paper WP-GE-13, Chair of Energy Economics and Public Sector Management (EE2), TU Dresden.
- Grande, O. S., and I. Wangensteen (2000) "Alternative Models for Congestion Management and Pricing Impact on Network planning and Physical Operation," *CIGRE*, Paris, Aug/Sept.
- Hogan, W. (2002a) "Financial Transmission Right Incentives: Applications Beyond Hedging." Presentation to HEPG Twenty-Eighth Plenary Sessions, May 31, <http://www.ksg.harvard.edu/people/whogan>.
- Hogan, W. (2002b) "Financial Transmission Right Formulations," Mimeo, JFK School of Government, Harvard Electricity Policy Group Harvard University, <http://www.ksg.harvard.edu/people/whogan>.
- Hogan, W., J. Rosellón and I. Vogelsang (2007), "Toward a Combined Merchant-Regulatory Mechanism for Electricity Transmission Expansion," Conference Proceedings, 9th IAEE European Energy Conference, Florence, Italy.
- Joskow. P. (2005). *The Difficult Transition to Competitive Electricity Markets in the U.S..* In *Electricity Deregulation: Choices and Challenges*, J. Griffin and S. Puller, eds., University of Chicago Press, Chicago.

- Joskow, P. and J. Tirole (2005) "Merchant Transmission Investment," *The Journal of Industrial Economics*, volume 53, issue 2, Page 233, June.
- Kristiansen, T. and J. Rosellón (2006) "A Merchant Mechanism for Electricity Transmission Expansion," *Journal of Regulatory Economics*, vol.29, no. 2, pp. 167-193, March.
- Laffont, J.J., and J. Tirole (1996) "Creating Competition Through Interconnections: Theory and Practice," *Journal of Regulatory Economics*, 10: 227-256.
- Léautier, T.-O. (2000) "Regulation of an Electric Power Transmission Company," *The Energy Journal*, vol. 21, no. 4, pp. 61-92.
- Leuthold, Florian, Hannes Weigt, and Christian von Hirschhausen (forthcoming): *ELMOD - Electricity Model Using Nodal Prices*. Dresden University of Technology, Chair of Energy Economics and Public Sector Management.
- Neuhoff, Karsten, Julian Barquinb, Maroeska G. Boots, Andreas Ehrenmann, Benjamin F. Hobbse, Fieke A.M. Rijkersf, and Miguel Va'zquez (2005): Network-constrained Cournot models of liberalized electricity markets: the devil is in the details. *Energy Economics* vol. 27 p. 495-525.
- Pérez-Arriaga, J. I., F. J. Rubio and J. F. Puerta Gutiérrez, et al. (1995) "Marginal Pricing of Transmission Services: An Analysis of Cost Recovery," *IEEE Transactions on Power Systems*, vol. 10, no. 1, February.
- Ramírez, J. C. and J. Rosellón (2002) "Pricing Natural Gas Distribution in Mexico," *Energy Economics*, vol. 24, no. 3, pp. 231-248.
- Rosellón, J. (2007), "A Regulatory Mechanism for Electricity Transmission in Mexico," *Energy Policy*, 35 (5): 3003-3014, May,
- Schweppe, Fred C., Caramanis, Michael C., Tabors, Richard D., and Roger E. Bohn (1988): *Spot Pricing Of Electricity*. Boston, Kluwer.
- Stigler, Heinz, and Christian Todem (2005): Optimization of the Austrian Electricity Sector (Control Zone of VERBUND APG) under the Constraints of Network Capacities by Nodal Pricing. In: *Central European Journal of Operations Research*, 13, 105-125.
- Vogelsang, I. (2001), "Price Regulation for Independent Transmission Companies," *Journal of Regulatory Economics*, vol. 20, no. 2, September.